

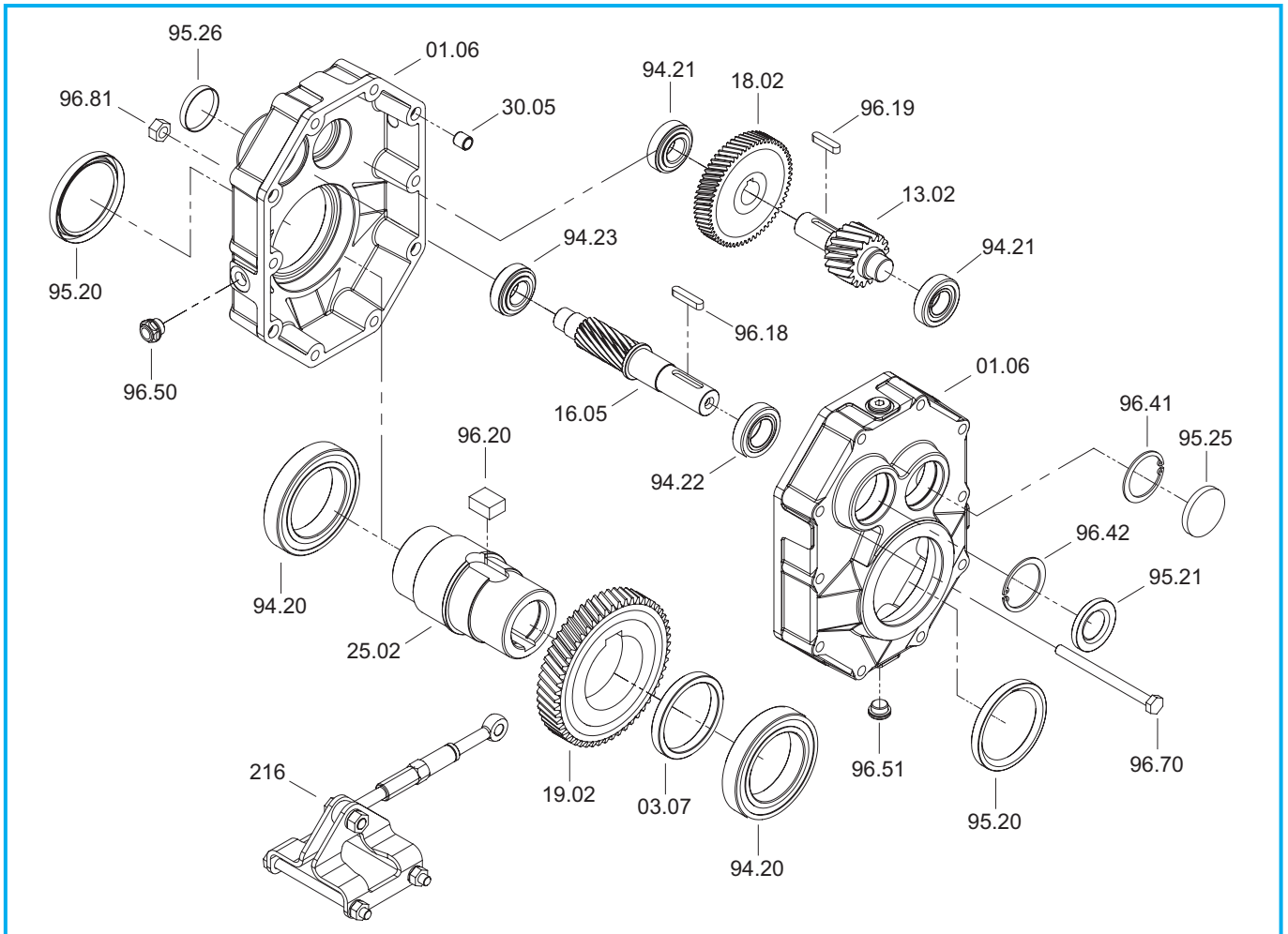

MA..B



MA	Rodamientos / Bearings / Roulements				Retenes / Oilseals / Bagues d'étanchéité	
	94.20	94.21	94.22	94.23	95.20	95.21
63B	6010 50/80/16	6303 17/47/14	6004 20/42/12	6203 17/40/12	50/65/8	20/42/7
80B	6012 60/95/18	30204 20/47/15.25	6205 25/52/15	6204 20/47/14	60/75/8	25/52/7
100B	6015 75/115/20	30205 25/52/16.25	32006 30/55/17	30205 25/52/16.25	75/95/10	30/55/7
125B	6018 90/140/24	30206 30/62/17.25	32008 40/68/19	30206 30/62/17.25	90/110/12	40/68/10
140B	6219 95/170/32	30207 35/72/18.25	30208 40/80/19.75	30207 35/72/18.25	95/125/12	40/80/10
160B	6222 110/200/38	32208 40/80/24.75	32209 45/85/24.75	32208 40/80/24.75	110/130/12	45/85/10
180B	6226 130/230/40	33210 50/90/32	32210 50/90/24.75	32209 45/85/24.75	130/160/12	50/90/10

MA..B

Dispositivo anti-retorno - Backstop device - Dispositif anti-dévireur

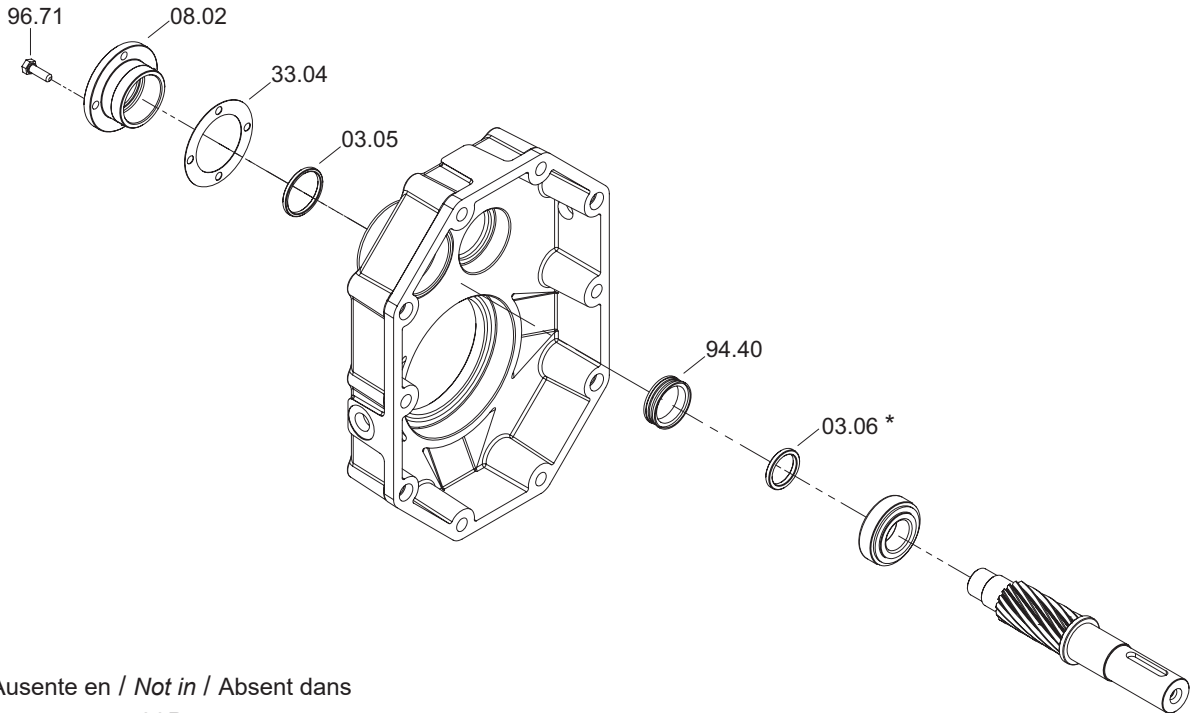

* Ausente en / Not in / Absent dans
63B
80B

MA	Rueda libre / Free wheel / Roue libre 94.40
63B	FE 423 Z
80B	FE 428 Z
100B	BF 50 Z 16
125B	BF 71 Z 16
140B	SF 31-13,5/12J
160B	BF 90 Z 21
180B	FE 8044 Z 19



3.14 Lista de recambios

3.14 Spare parts list

3.14 Liste des pièces détachées

Cuando se ordene un recambio, especificar siempre el número particular de cada pieza referenciado en el despiece (ver gráfico de despiece) fecha (1), n° de código (2) y n° variable (3). (Ver placa de características).

When ordering please specify the spare part number (see exploded view) as well as the date (1), the article number (2) and the variant number (3) (see plate).

Lors de la commande de pièces détachées, toujours rappeler le n° de la pièce (voir plan éclaté), la date (1), le n° de code (2) et le n° de la variante (3). (Voir plaquette signalétique).

